

Front View

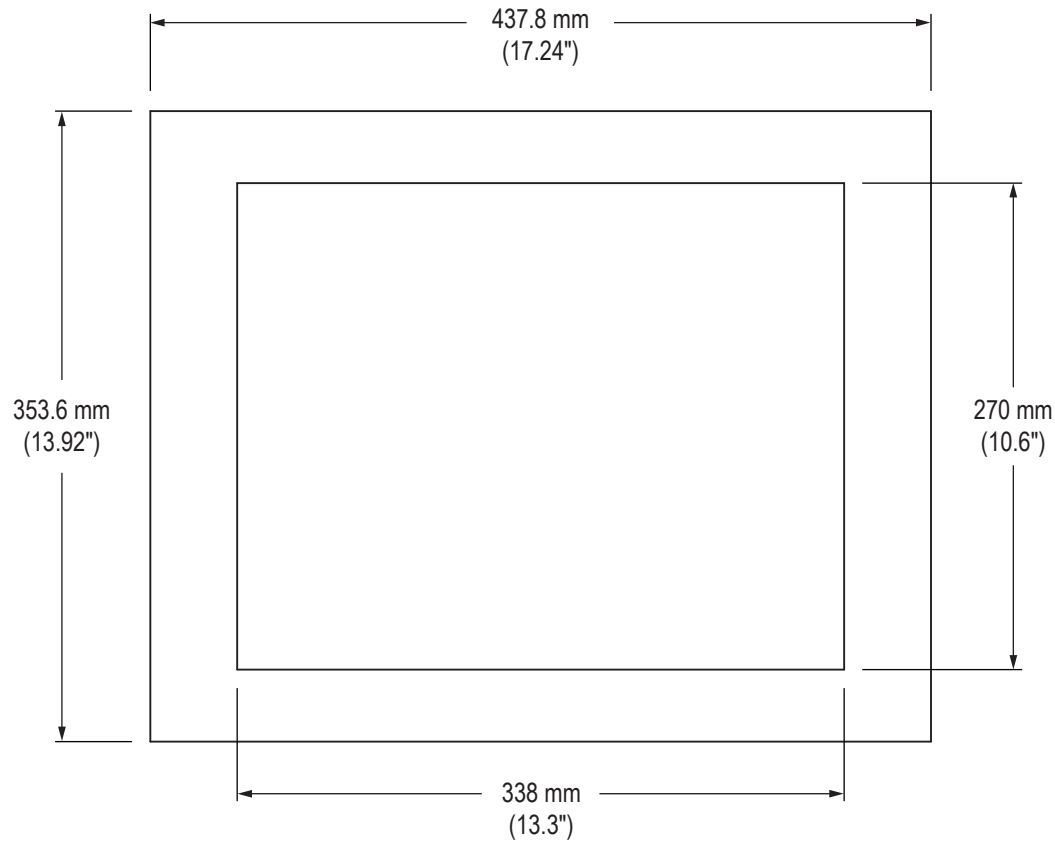

Side View

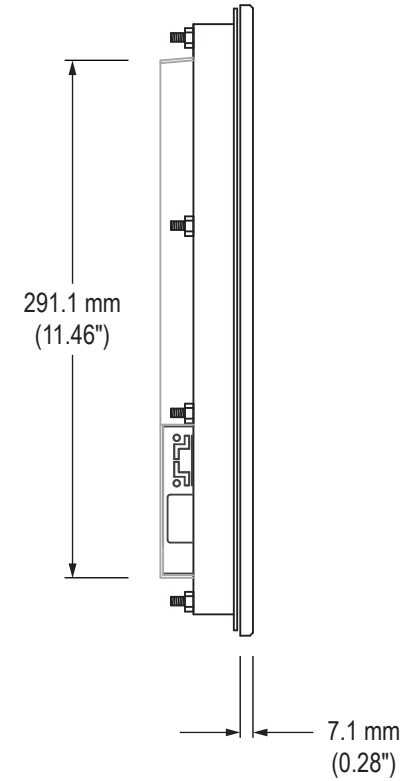

Rear View (showing Cutout Dimensions)

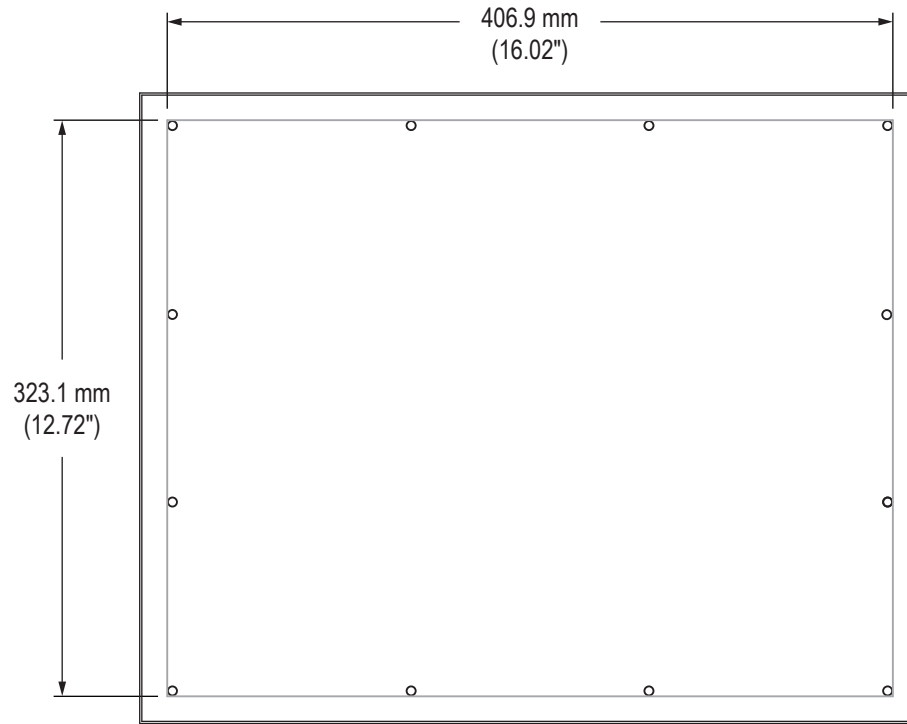

Bottom View

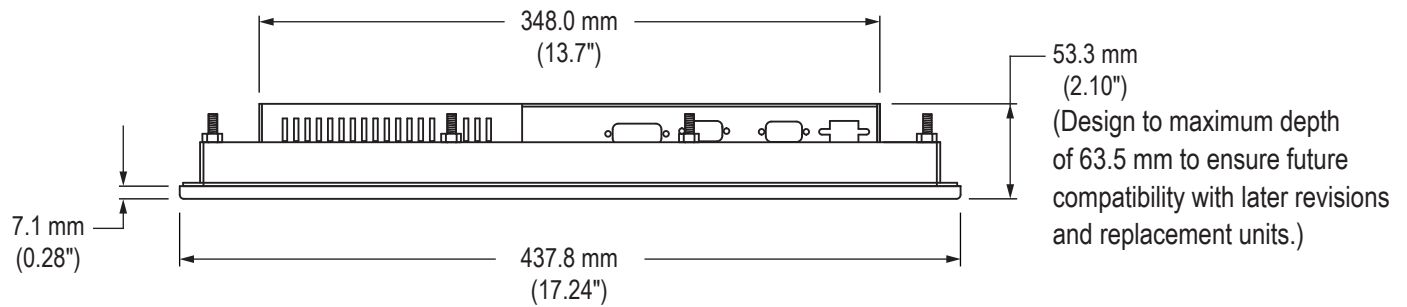

Cable Connections

Rear View

100 mm VESA
MOUNTING PATTERN
(M4 SCREWS PROVIDED,
16 mm MAXIMUM DEPTH
OF SCREW)

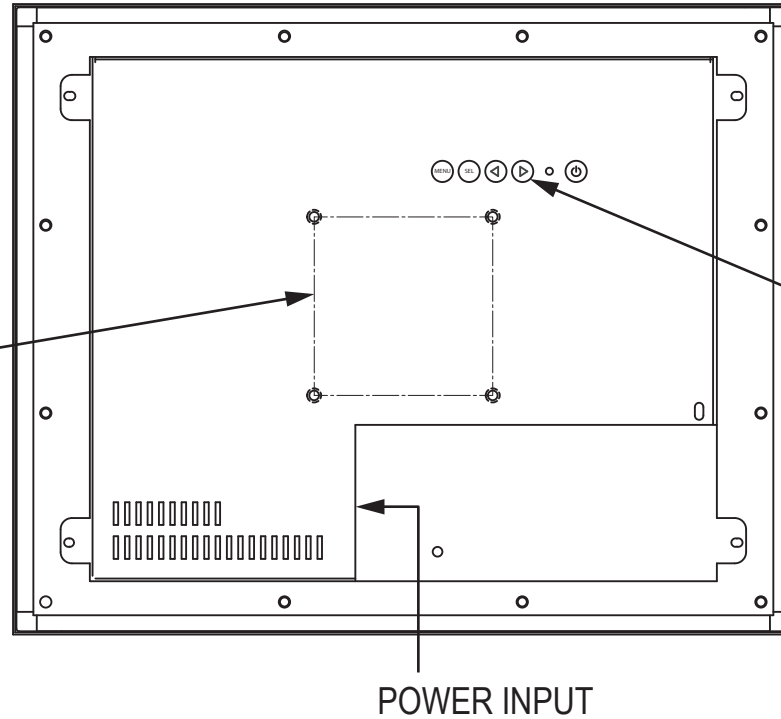

CONTROL PANEL
BUTTONS

POWER INPUT

Bottom View

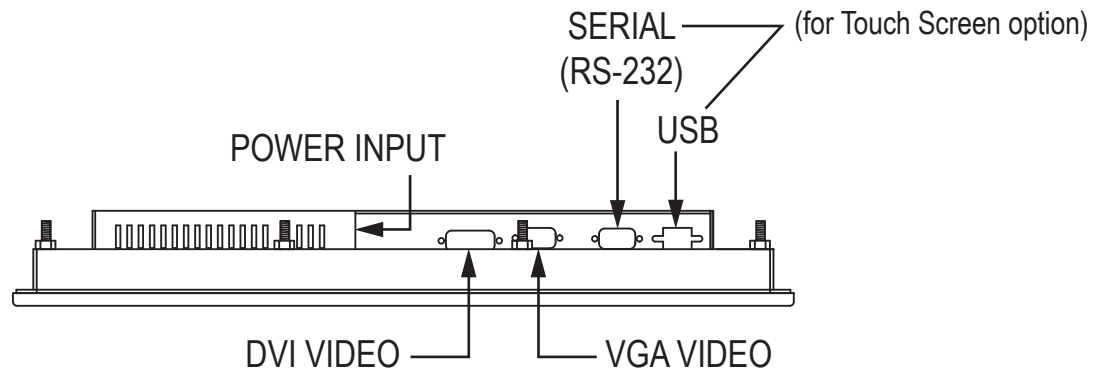

SERIAL (RS-232) (for Touch Screen option)

POWER INPUT

USB

DVI VIDEO

VGA VIDEO